

RABBIT HUTCH PLANS

Drawing	Description
RH-001.....	floor
RH-002	panelling and braces
RH-003	legs
RH-004	partition
RH-005	front panel
RH-006	door
RH-007	roof
RH-008	assembly - frame
RH-009	assembly - panels
RH-010	assembly - partition
RH-011	assembly - roof
RH-012	assembly - doors

Notes:

The drawings are scaled as stated when printed on A2 paper, if an A2 printer is not available set the print output to tile or fit to page, in which case the resulting print will not be to scale.

The dimensions are nominal and no allowance has been made for variations in timber sizes or inaccuracies in making. Therefore it is recommended that the hutch be built in the following stages, adjusting the components as required.

- construct floor, fit legs.
- cut and fit braces at top.
- cut panels to suit and assemble.
- cut and fit partition.
- construct front panel and door to fit.
- construct roof and cover with felt.
- fit door and roof.

If required a simple prop can be added to hold the roof open. obtain a suitable piece of wood which will fit between the side brace and side panel. Cut to length, drill a hole at one end then drill a hole in the side brace in a suitable position, insert a screw through both into the side panel ensuring the prop moves easily. Add another screw to support the prop in the closed position if necessary.

DRAWING No
RH-001

SHT 1 OF 12

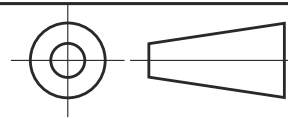

THIRD ANGLE PROJECTION

ISSUE	REVISION	DATE

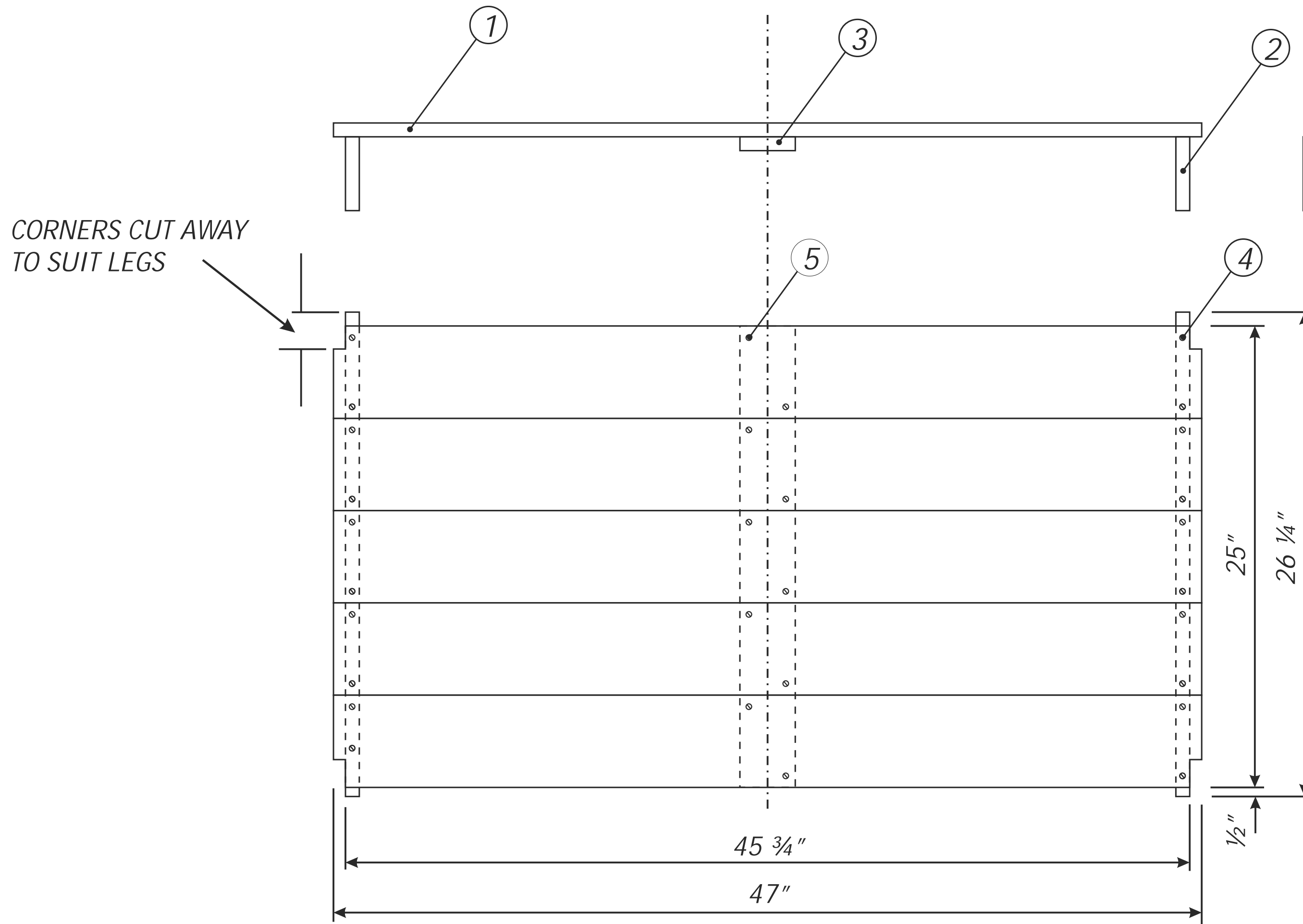

1	Floor boards	5" x 3/4" x 47"	5
2	Side supports	4" x 3/4" x 25"	2
3	Center support	4" x 3/4" x 25"	14
4	CSK Screws	No 8 x 1 1/2"	20
5	CSK Screws	No 8 x 1"	10
No.	DESCRIPTION	MATERIAL	QTY



www.rays-shed.co.cc

TITLE
RABBIT HUTCH
FLOOR

DATE:

ALL DIMENSIONS IN INCHES

TOLERANCES
GENERAL: +/- 1/8"

DRAWN

CHECKED

A2 SCALE: 1:5

DRAWING No
RH-001

SHT 1 OF 12

DRAWING No
RH-002

SHT 2 OF 12

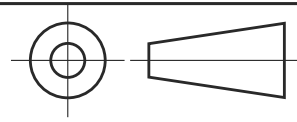

THIRD ANGLE PROJECTION

ISSUE	REVISION	DATE

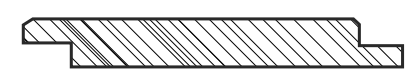
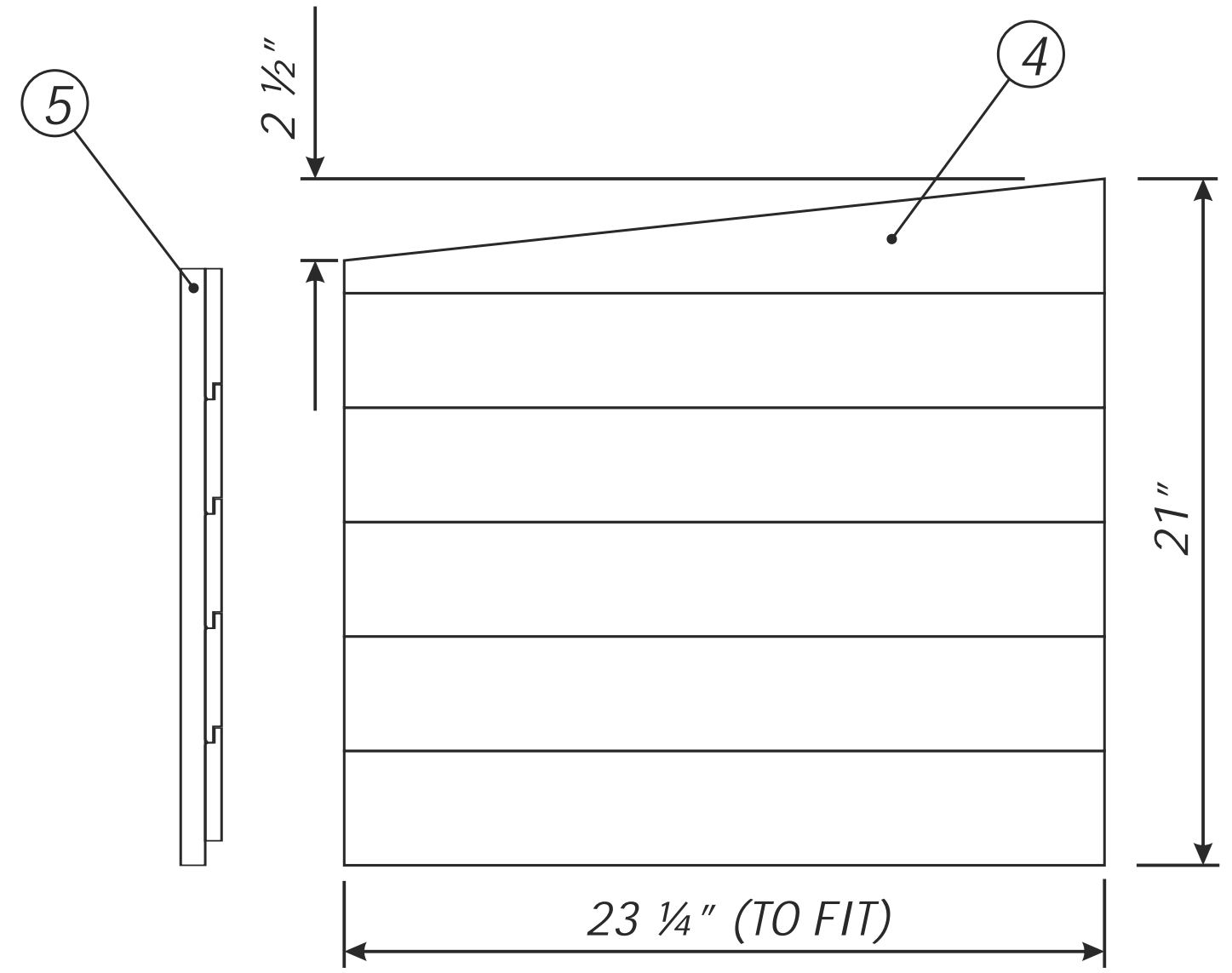
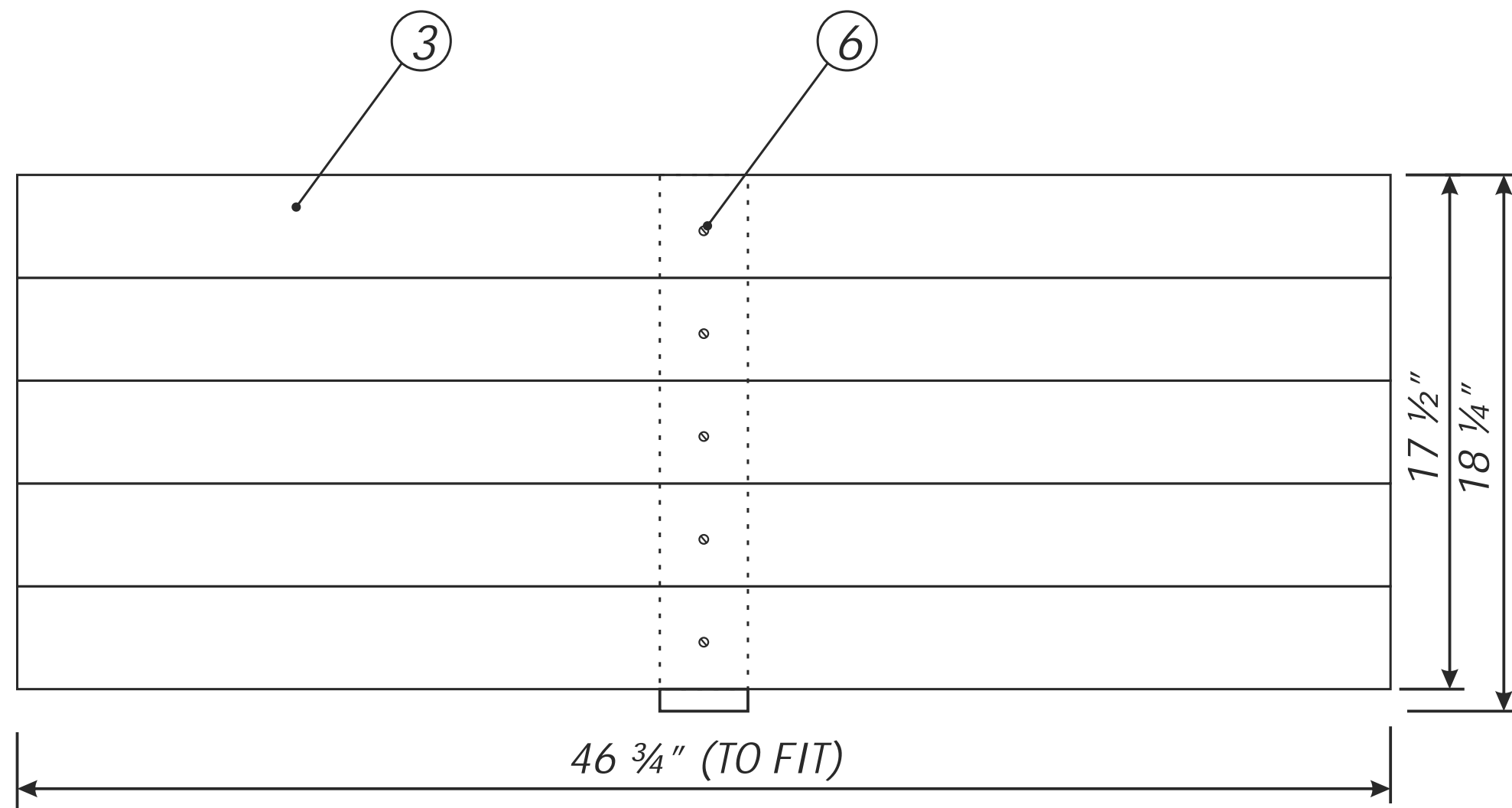
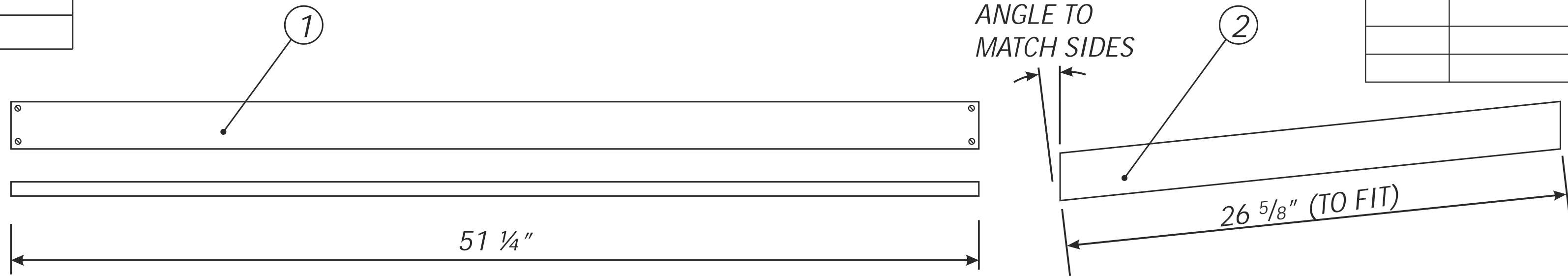

END VIEW OF BOARDING SCALE 1:2

1	Cross brace	2 1/2 x 1/2" x 52"	2
2	Side brace	2 1/2 x 1/2" x 27"	2
3	Rear panel board	4" x 1/2" x 48"	5
4	Side panel board	4" x 1/2" x 24"	12
5	Center support	3" x 3/4" x 18"	1
6	CSK screw	No. 8 x 1"	5
No.	DESCRIPTION	MATERIAL	QTY



www.rays-shed.co.cc

TITLE
RABBIT HUTCH
SIDE & REAR PANELING

DATE:

ALL DIMENSIONS IN INCHES

TOLERANCES
GENERAL: +/- 1/8"

DRAWN

CHECKED

A2 SCALE: 1:5

DRAWING No
RH-002

SHT 2 OF 12

DRAWING No
RH-003

SHT 3 OF 12

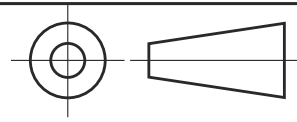

THIRD ANGLE PROJECTION

ISSUE	REVISION	DATE

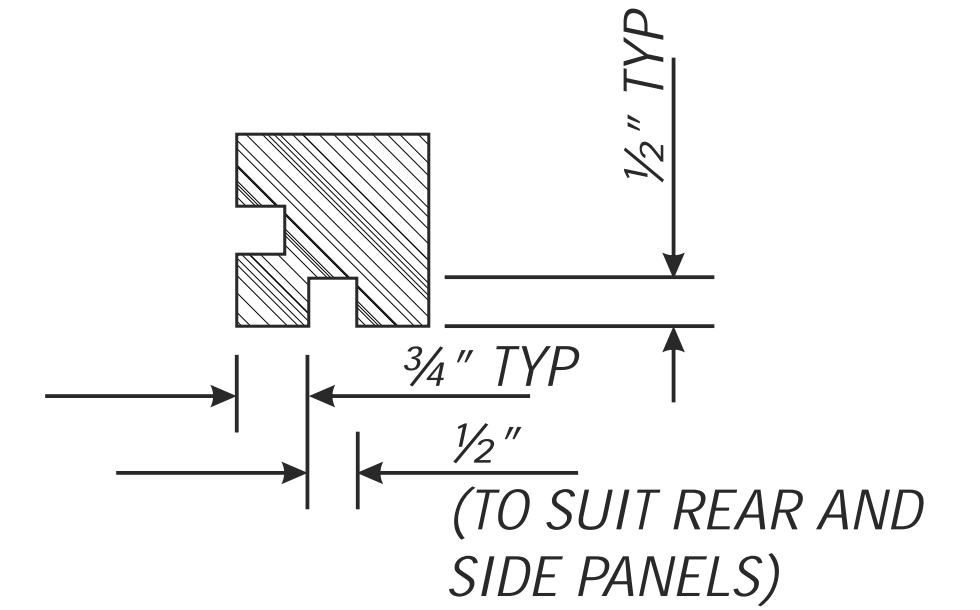
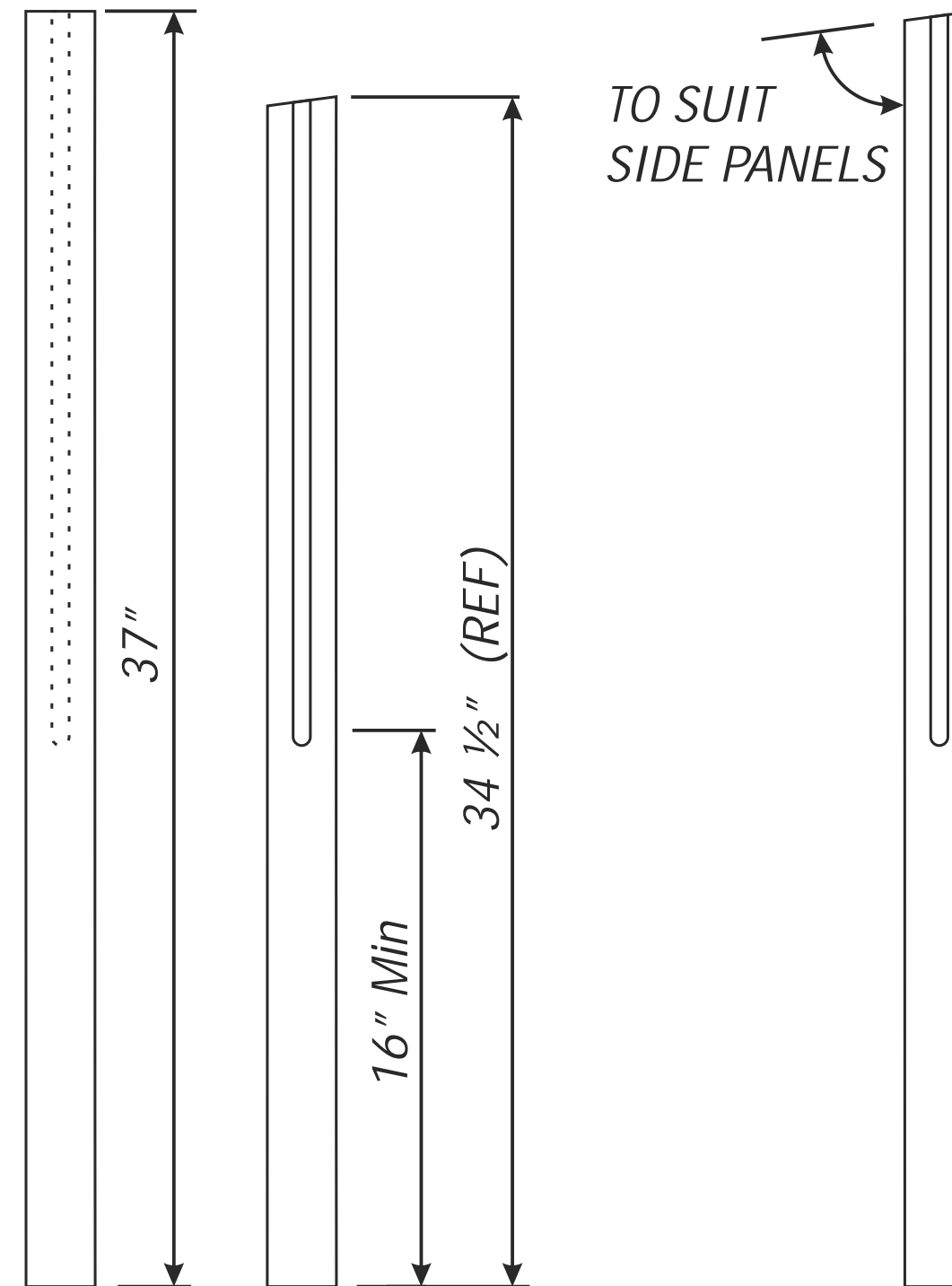
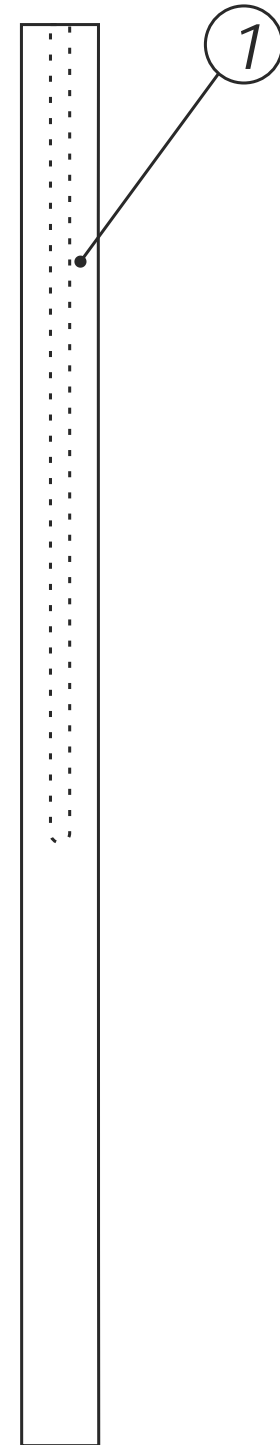

1/2 X SIZE

NOTE THAT FRONT RH LEG HAS ONLY ONE SLOT

1	Legs	2" x 2" x 37"	4
No.	DESCRIPTION	MATERIAL	QTY



www.rays-shed.co.cc

TITLE
RABBIT HUTCH
LEGS

DATE:

ALL DIMENSIONS IN INCHES

TOLERANCES
GENERAL: +/- 1/8"

DRAWN

CHECKED

A2 SCALE: 1:5

DRAWING No
RH-003

SHT 3 OF 12

DRAWING No
RH-004

SHT 4 OF 12

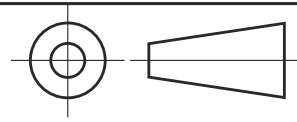

THIRD ANGLE PROJECTION

ISSUE	REVISION	DATE

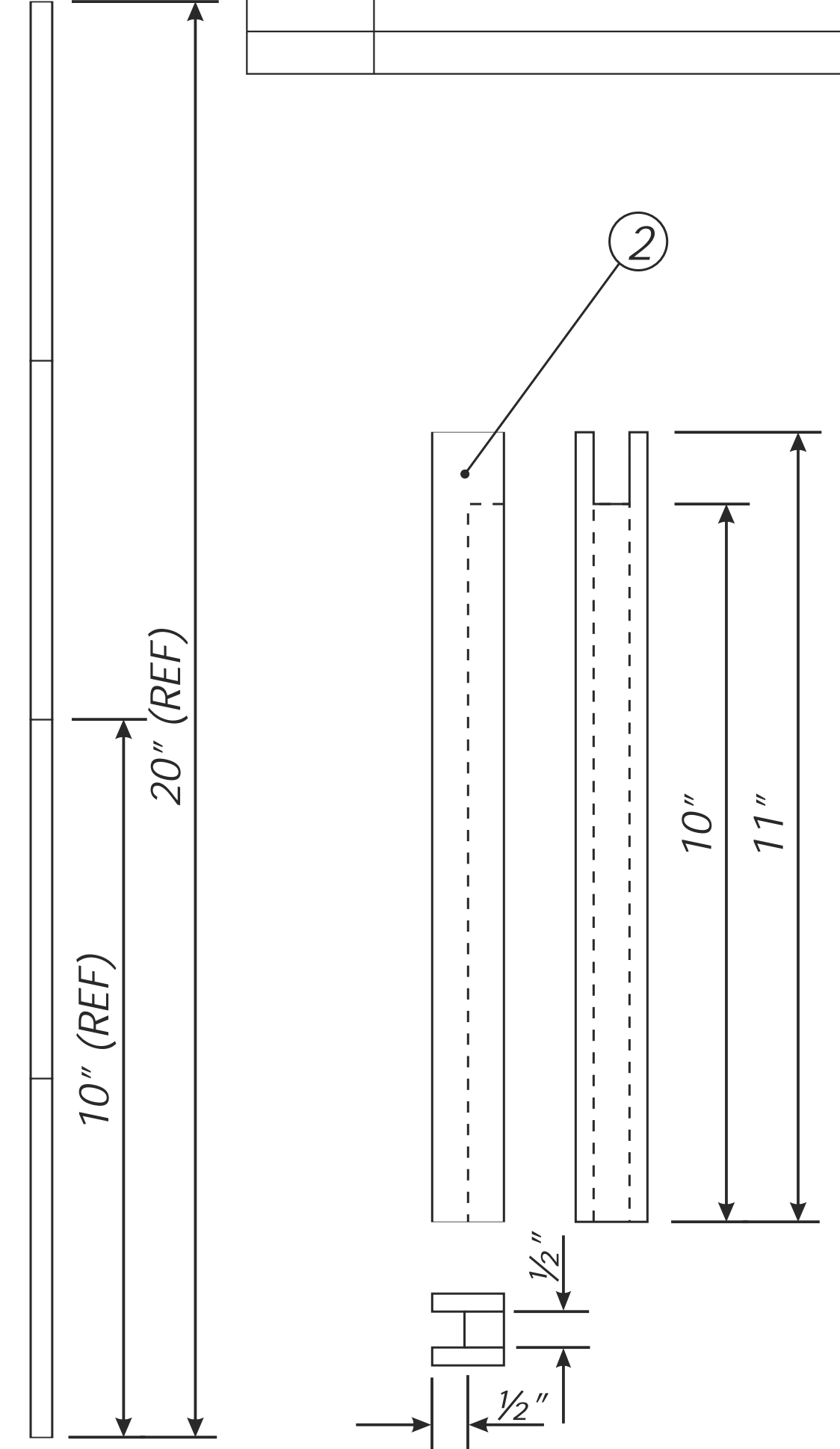
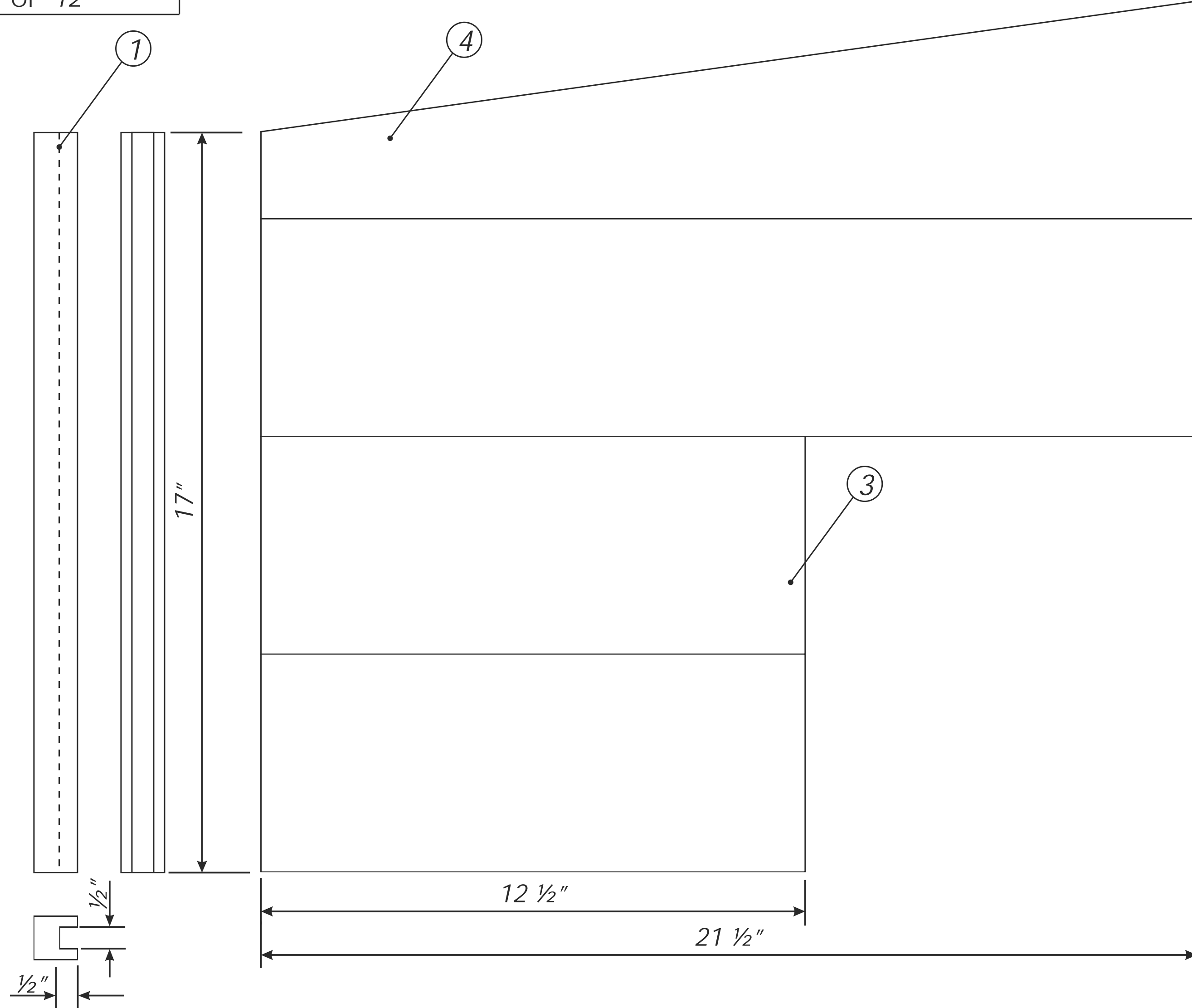

1	Rear upright	1 x 1" x 17"	1
2	Center upright	1x 1" x 11"	1
3	Lower dividing panel	5" x 1/2" x 10 1/2"	2
4	Upper dividing panel	5" x 1/2" x 21 1/2"	2
No.	DESCRIPTION	MATERIAL	QTY



www.rays-shed.co.cc

TITLE
RABBIT HUTCH
DIVIDER

DATE:

ALL DIMENSIONS IN INCHES

TOLERANCES
GENERAL: +/- 1/8"

DRAWN

CHECKED

A2 SCALE: 1:2

DRAWING No
RH-004

SHT 4 OF 12

DRAWING No
RH-005

SHT 5 OF 12

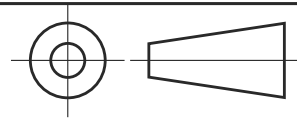

THIRD ANGLE PROJECTION

ISSUE	REVISION	DATE

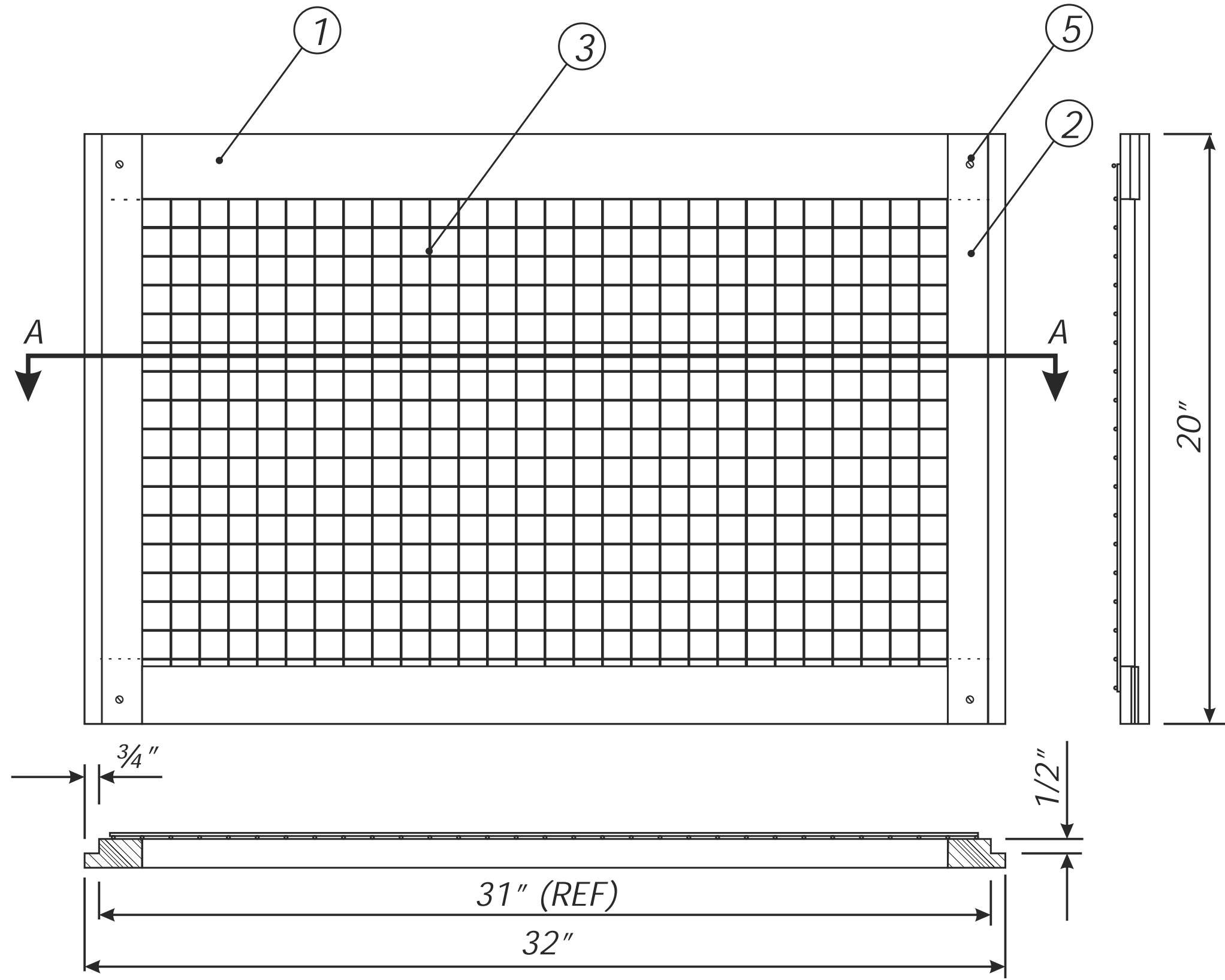

SECTION A-A

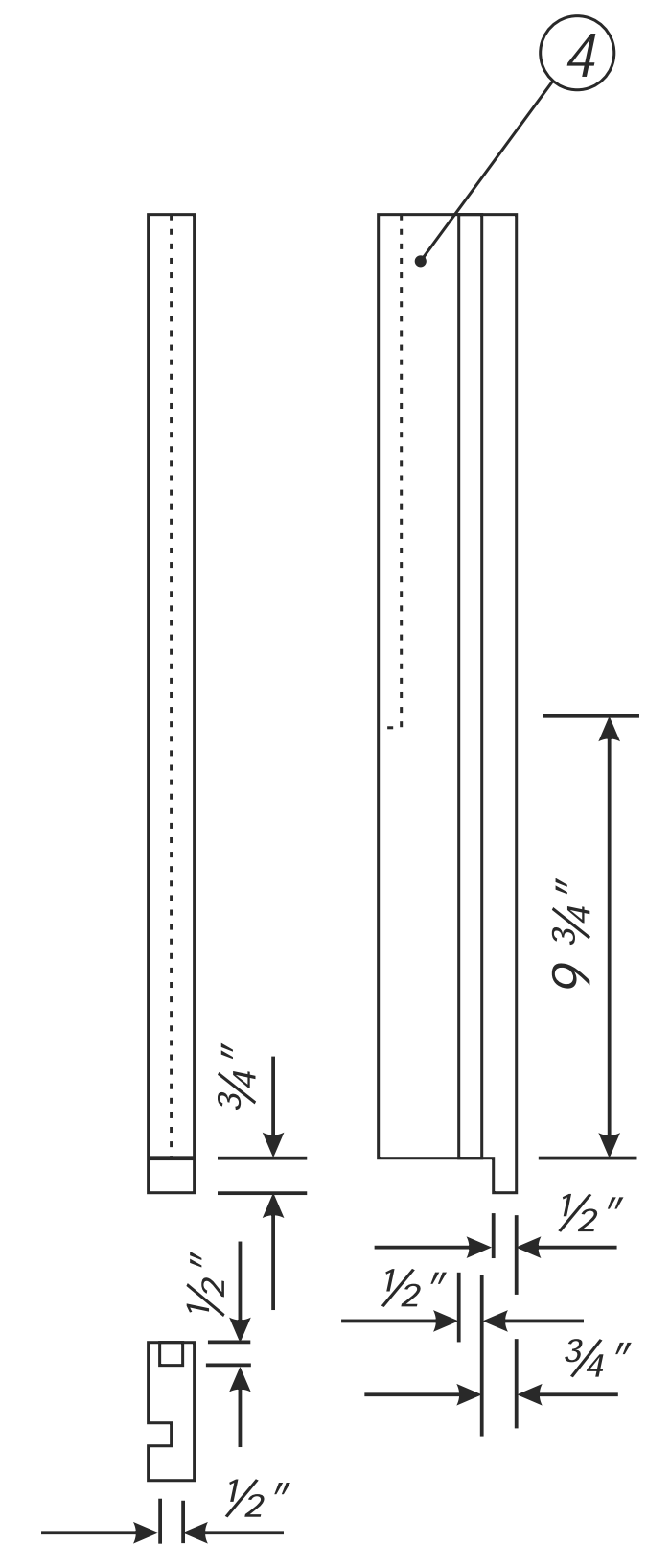

FRONT UPRIGHT

1	Upper and lower rails	2" x 3/4" x 32"	2
2	Side rails	2" x 3/4" x 20 1/2"	2
3	Wire mesh		1
4	Front upright	3" x 1" x 25"	1
5	CSK Screws	No 8 x 5/8"	4
6	Staples	5/8"	
No.	DESCRIPTION	MATERIAL	QTY



www.rays-shed.co.cc

TITLE
RABBIT HUTCH
FRONT PANEL

DATE:

ALL DIMENSIONS IN INCHES

TOLERANCES
GENERAL: +/- 1/8"

DRAWN

CHECKED

A2 SCALE: 1:4

DRAWING No
RH-005

SHT 5 OF 12

DRAWING No
RH-006

SHT 6 OF 12

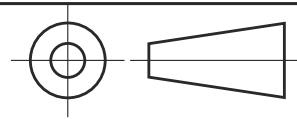

THIRD ANGLE PROJECTION

ISSUE	REVISION	DATE

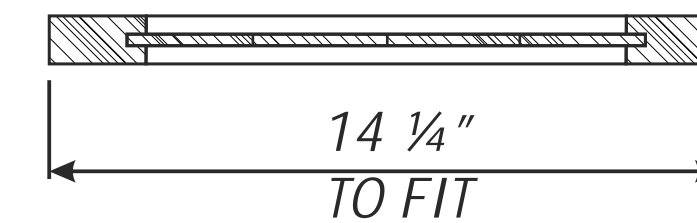
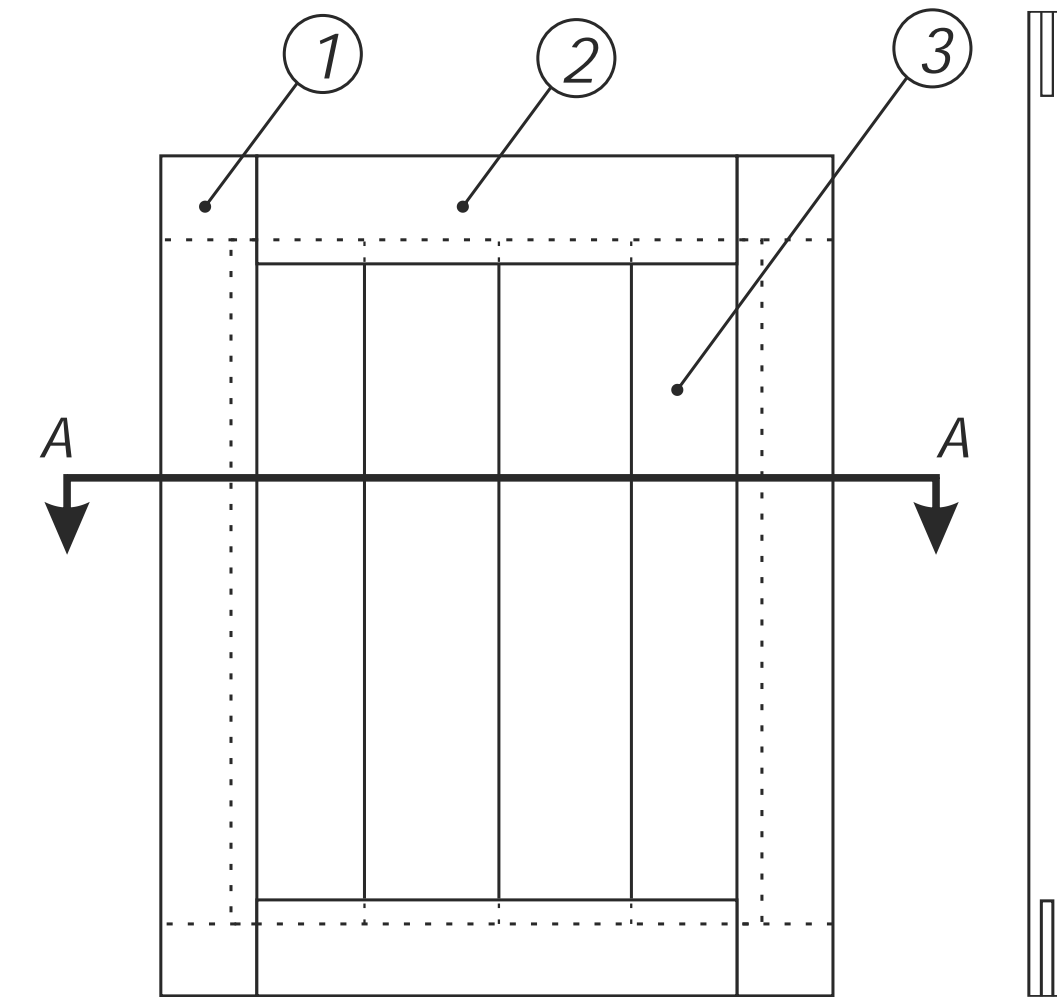
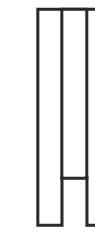
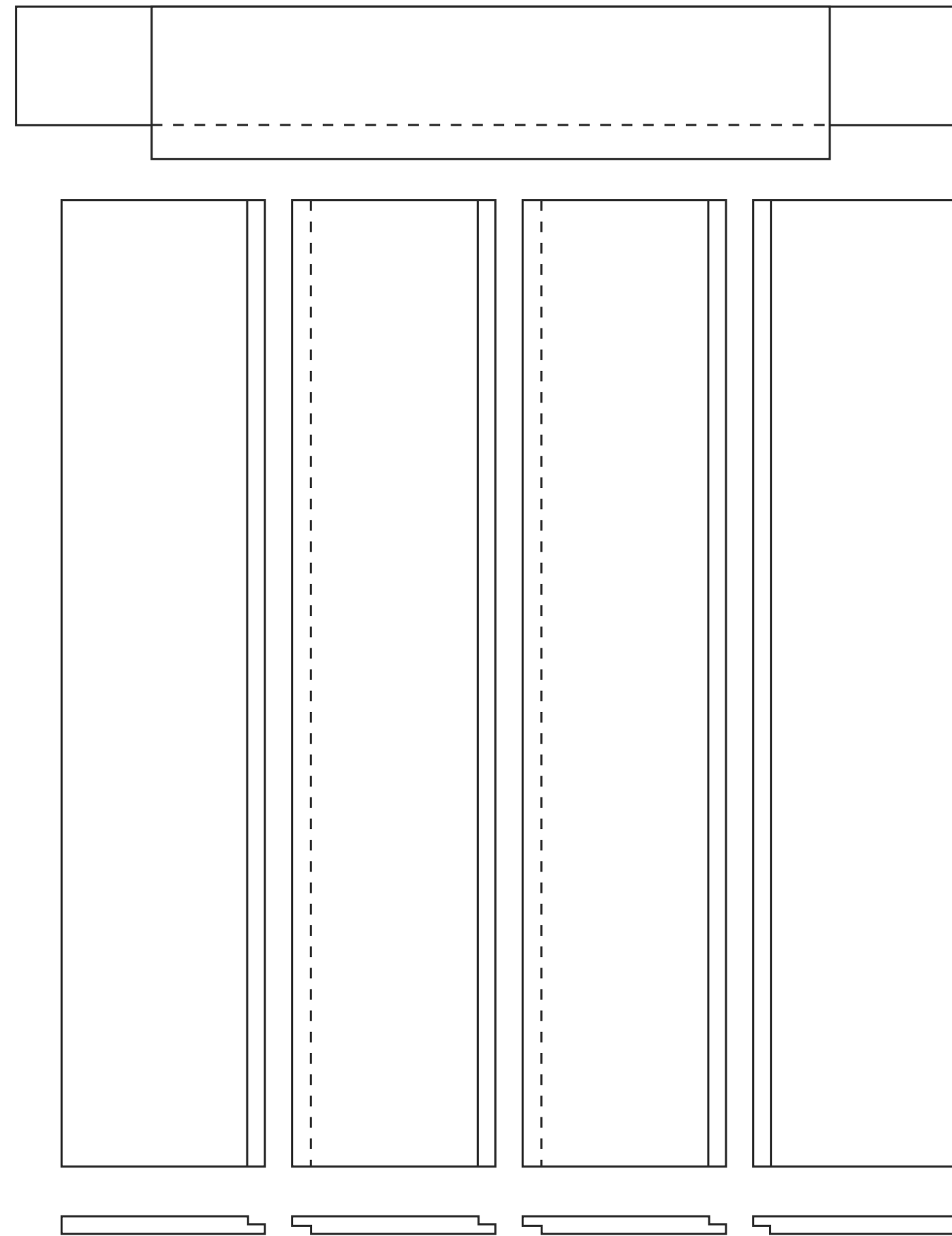
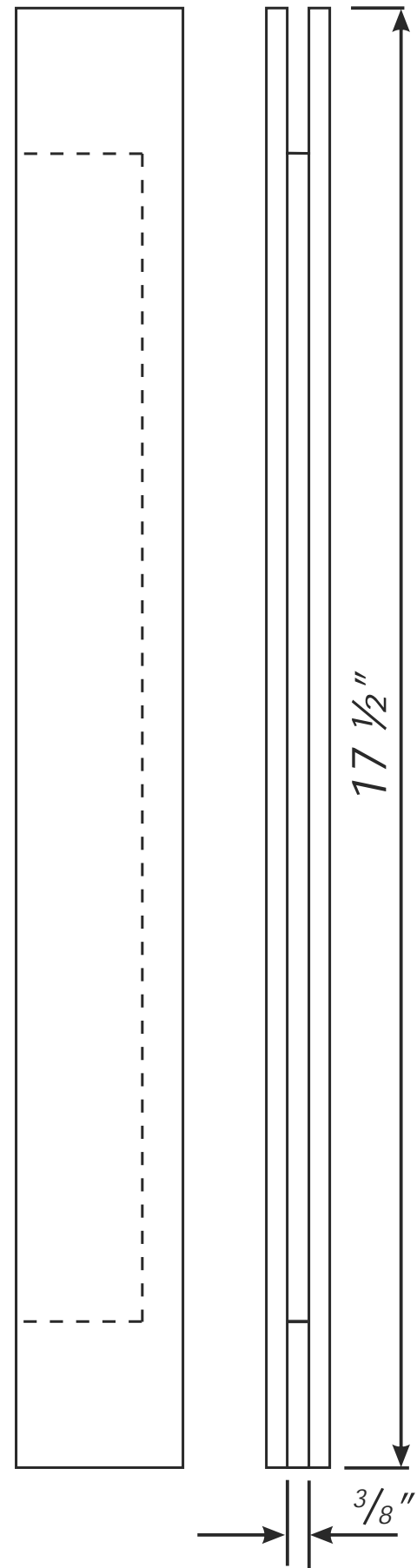

SECTION A-A

1	Door sides	2" x 3/4" x 32"	2
2	Door top and bottom	2" x 3/4" x 17 1/2"	2
3	Door panels	3" x 3/8" x 14 1/4"	4
4	CSK Screws	No 8 x 5/8"	4
No.	DESCRIPTION	MATERIAL	QTY



www.rays-shed.co.cc

TITLE
RABBIT HUTCH
DOOR

DATE:

ALL DIMENSIONS IN INCHES

TOLERANCES
GENERAL: +/- 1/8"

DRAWN

CHECKED

A2 SCALE: 1:2

DRAWING No
RH-006

SHT 6 OF 12

DRAWING No
RH-007

SHT 7 OF 12

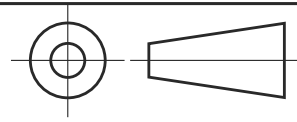

THIRD ANGLE PROJECTION

ISSUE	REVISION	DATE

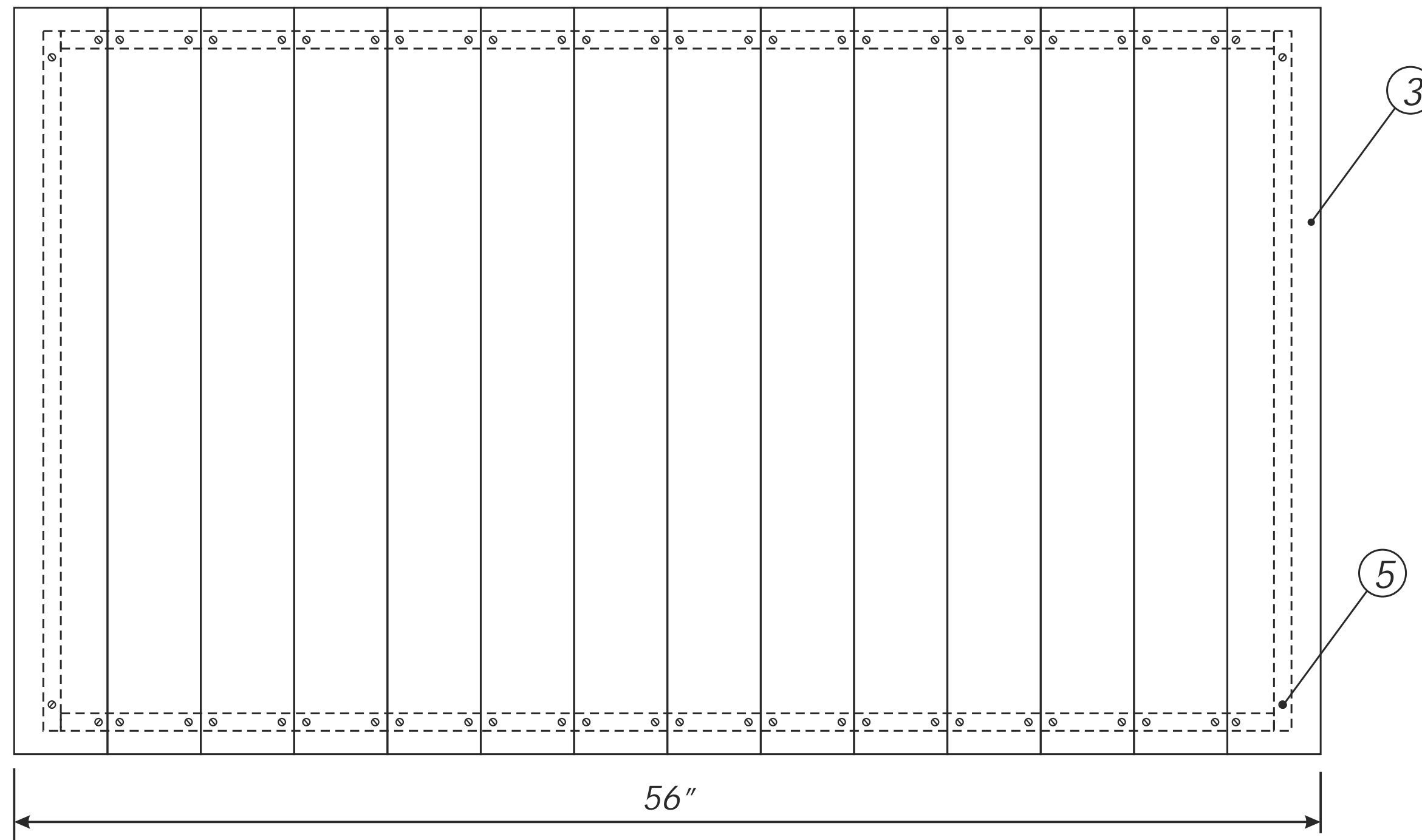
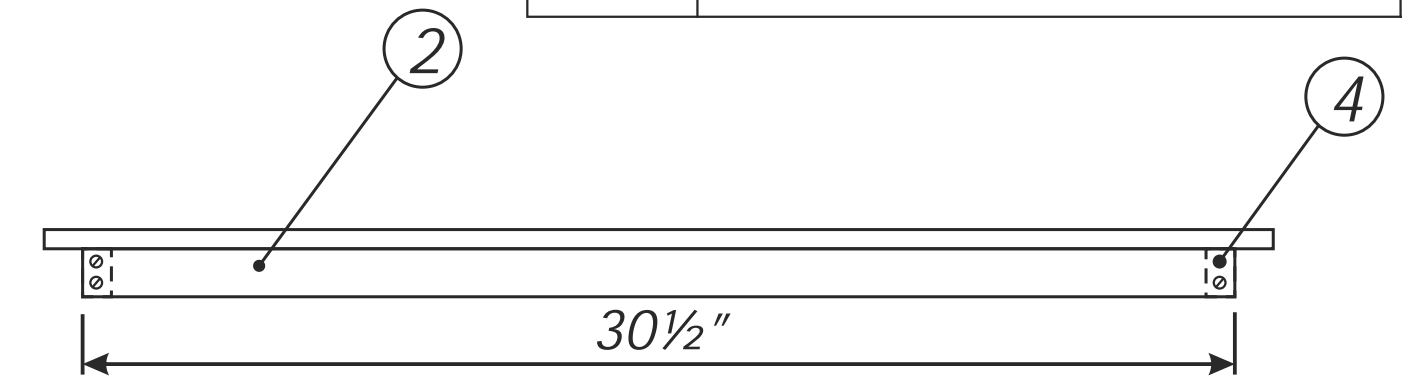
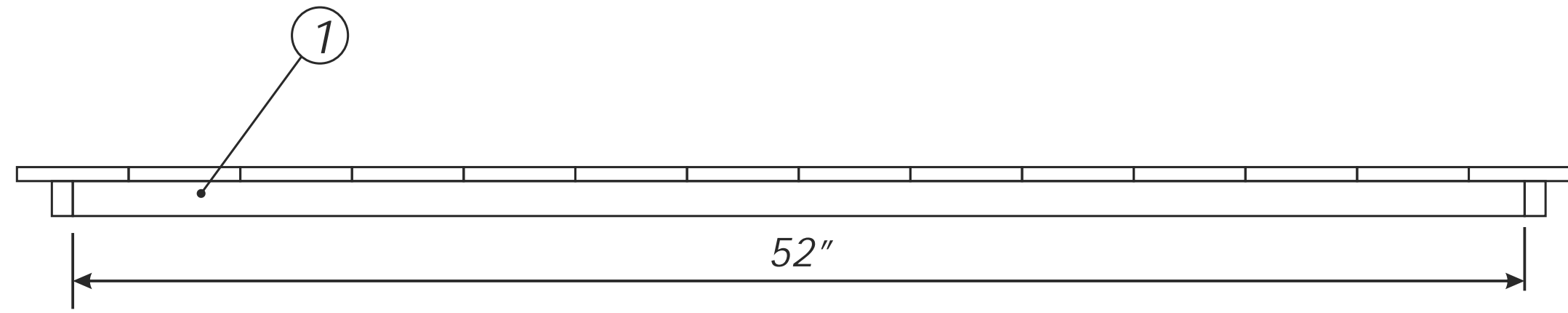

1	Front & rear frame members	1 1/4" x 3/4" x 52"	2
2	Side frame members	1 1/4" x 3/4" x 30 1/2"	2
3	Roof boards	4" x 1/2" x 32"	14
4	CSK Screws	No 8 x 1 1/2"	8
5	CSK Screws	No 8 x 1"	32
No.	DESCRIPTION	MATERIAL	QTY



www.rays-shed.co.cc

TITLE
RABBIT HUTCH
ROOF

DATE:

ALL DIMENSIONS IN INCHES

TOLERANCES
GENERAL: +/- 1/8"

DRAWN

CHECKED

A2 SCALE: 1:1

DRAWING No
RH-007

SHT 7 OF 12

DRAWING No
RH-008

SHT 8 OF 12

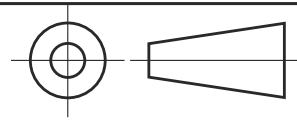

THIRD ANGLE PROJECTION

ISSUE	REVISION	DATE

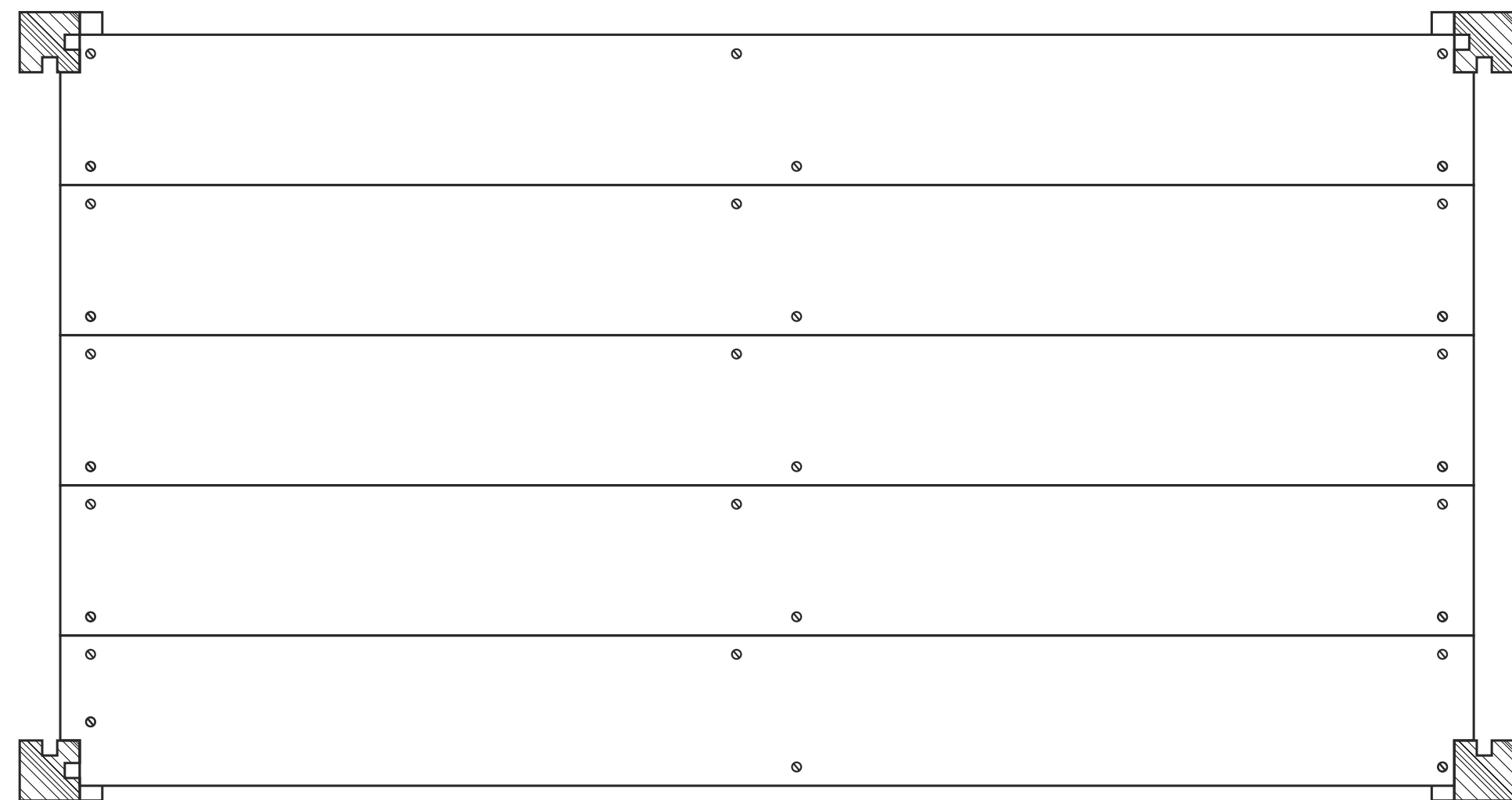
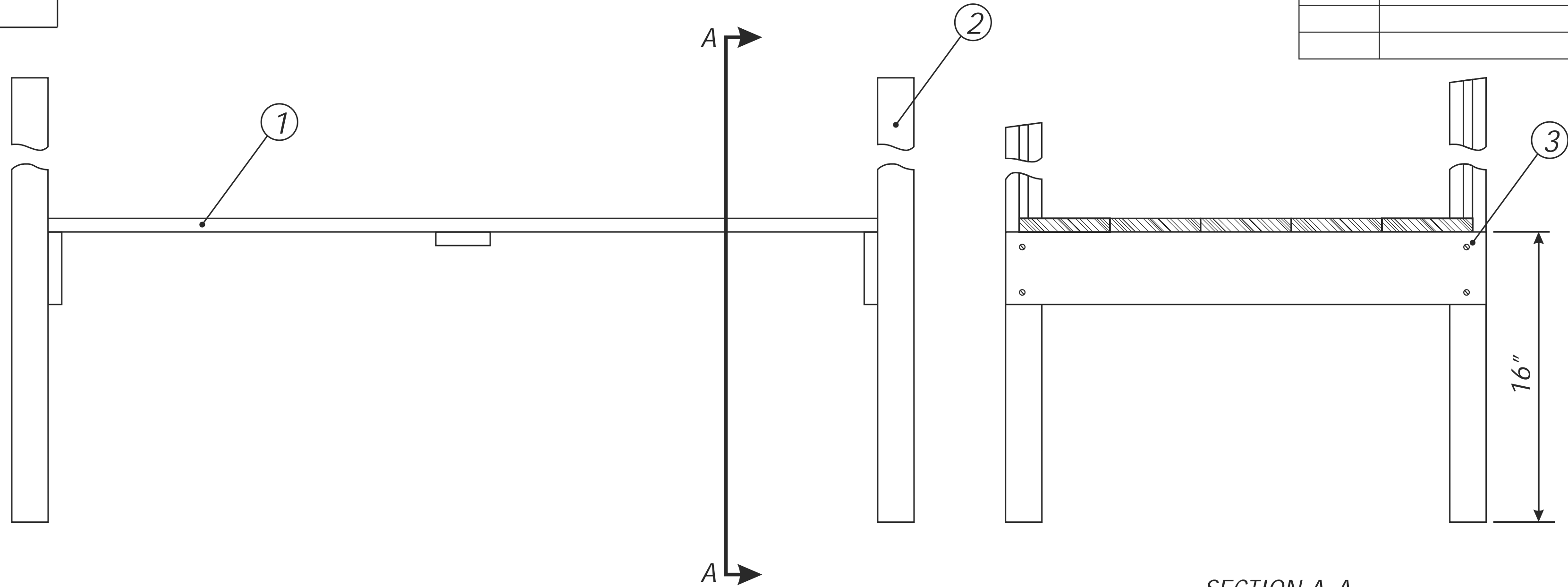

1	Floor	Drg. RH-001	1
2	Legs	Drg. RH-003	4
3	CSK Screws	No 8 x 1 1/2"	8
No.	DESCRIPTION	MATERIAL	QTY



www.rays-shed.co.cc

TITLE
RABBIT HUTCH
ASSEMBLY (Frame)

DATE:

ALL DIMENSIONS IN INCHES

TOLERANCES
GENERAL: +/- 1/8"

DRAWN

CHECKED

A2 SCALE: 1:5

DRAWING No
RH-008

SHT 8 OF 12

DRAWING No
RH-009

SHT 9 OF 12

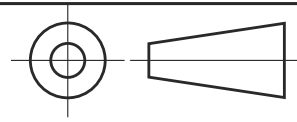

THIRD ANGLE PROJECTION

ISSUE	REVISION	DATE

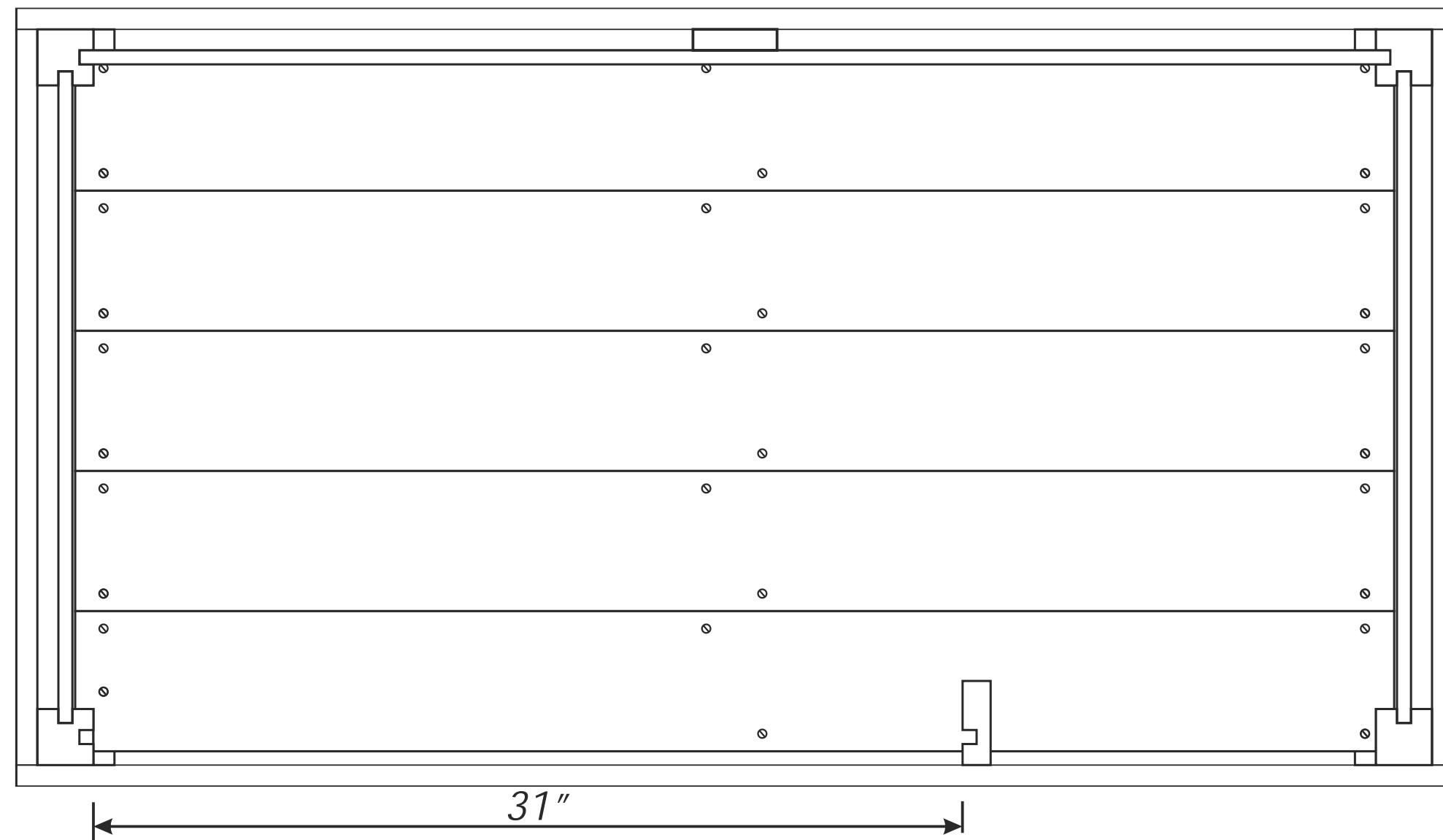
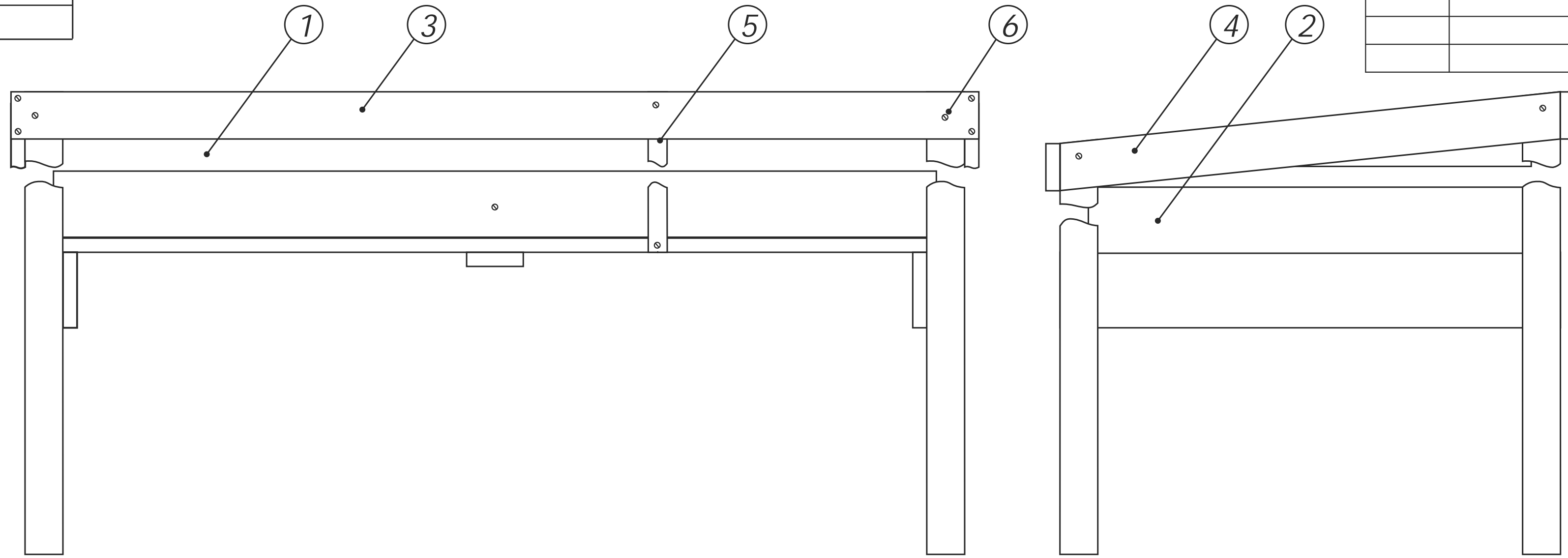

1	Rear panel	DRG RH-002	1
2	Side panels	DRG RH-002	2
3	Cross brace	DRG RH-003	2
4	Side brace	DRG RH-003	2
5	Front upright	DRG RH-005	1
6	CSK screws	No 8 x 1 1/2"	18
No.	DESCRIPTION	MATERIAL	QTY



www.rays-shed.co.cc

TITLE
RABBIT HUTCH
ASSEMBLY (Panels)

DATE:

ALL DIMENSIONS IN INCHES

TOLERANCES
GENERAL: +/- 1/8"

DRAWN

CHECKED

A2 SCALE: 1:5

DRAWING No
RH-009

SHT 9 OF 12

DRAWING No
RH-010

SHT 10 OF 12

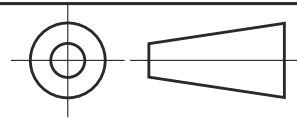

THIRD ANGLE PROJECTION

ISSUE	REVISION	DATE

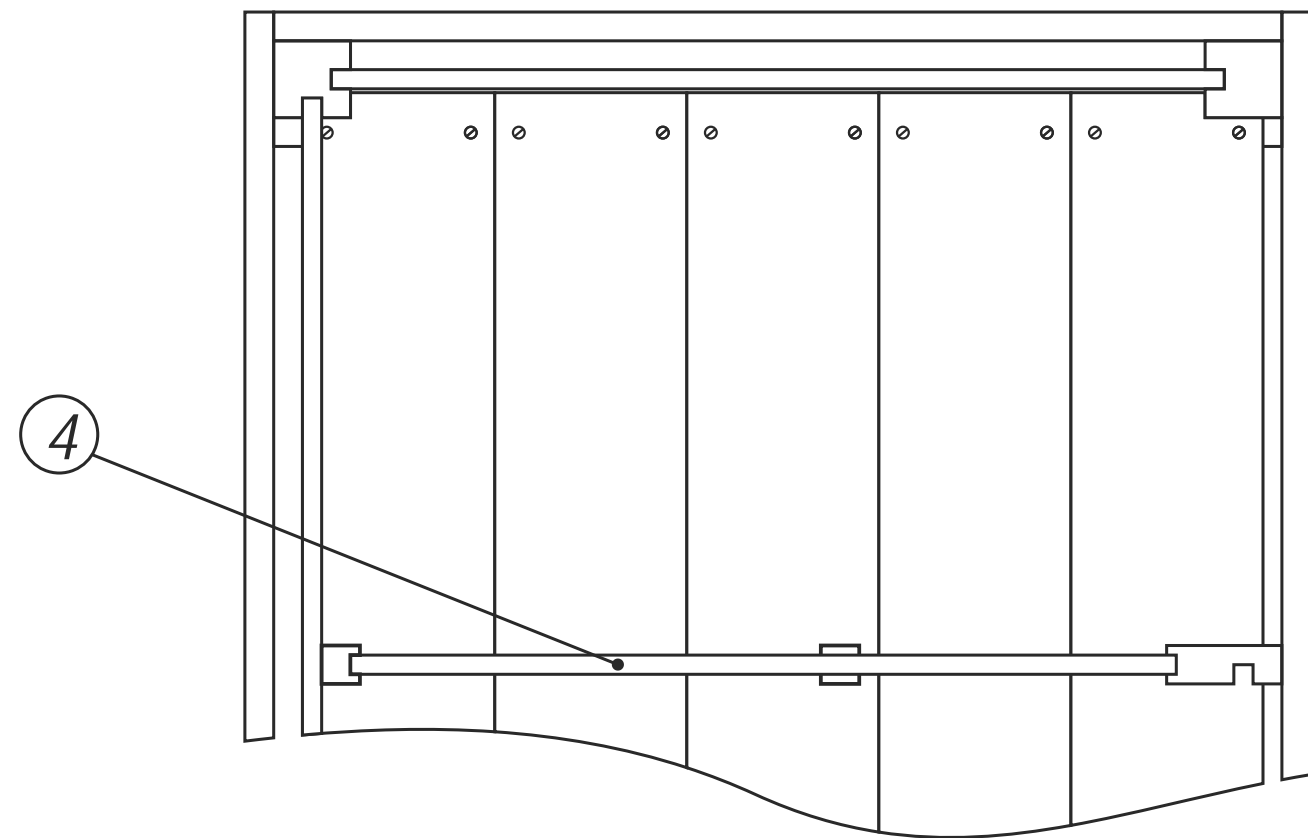
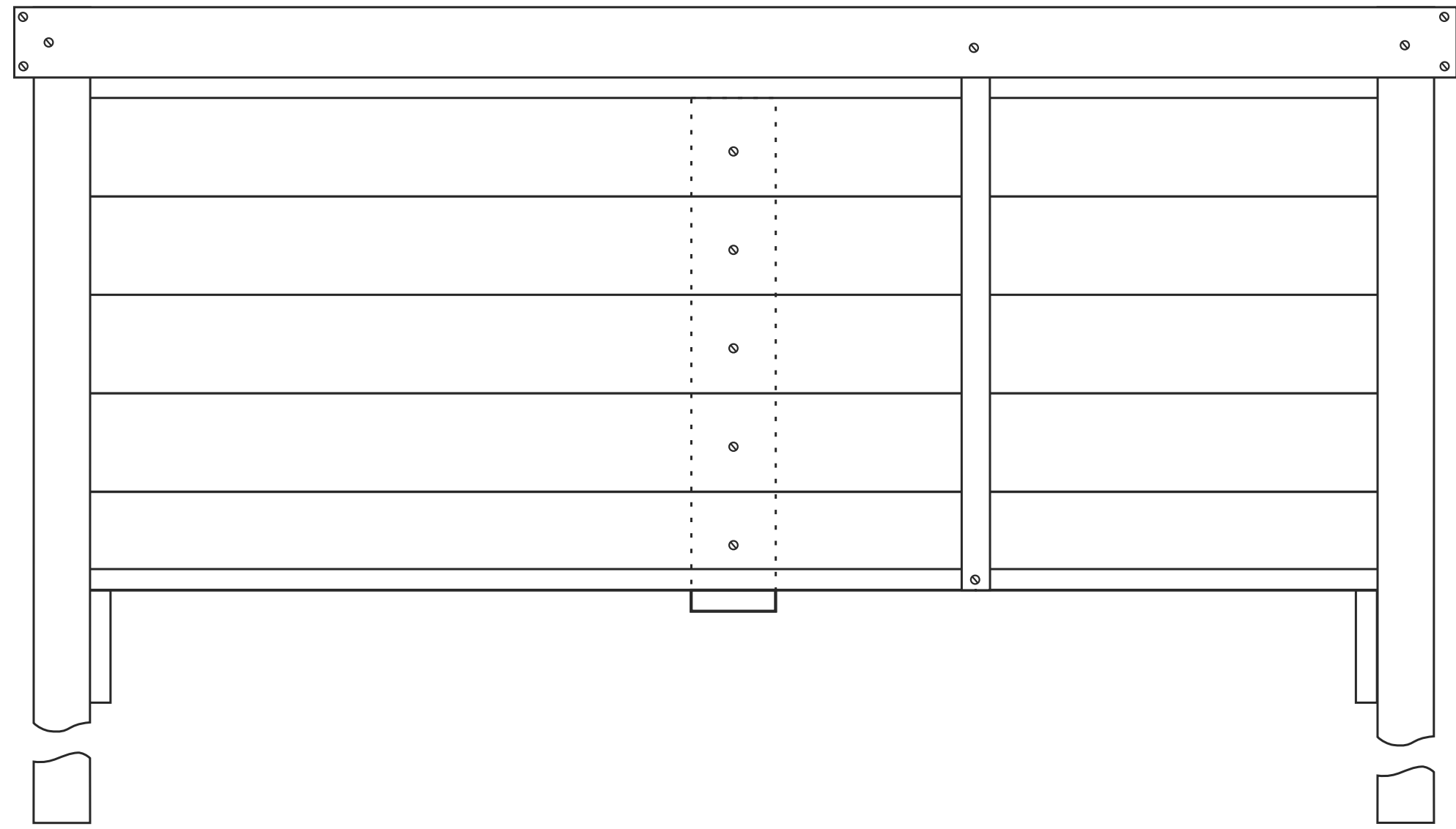
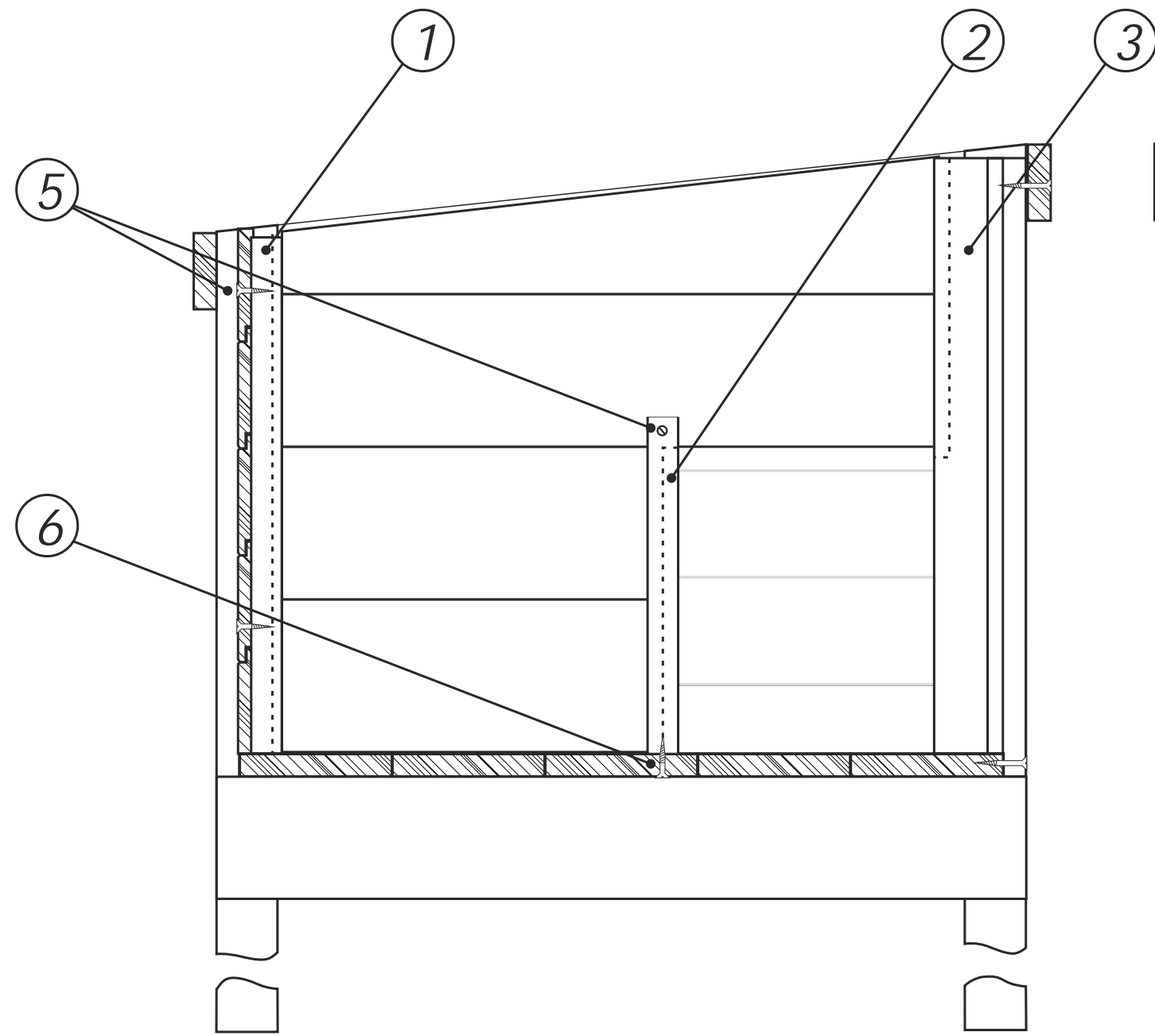

1	Rear upright	DRG RH-004	1
2	Center upright	DRG RH-004	1
3	Front upright	DRG RH-005	1
4	Partition boards	DRG RH-004	4
5	CSK screws	No 8 x 1"	3
6	CSK screws	No 8 x 1 1/2"	1
No.	DESCRIPTION	MATERIAL	QTY



www.rays-shed.co.cc

TITLE
RABBIT HUTCH
ASSEMBLY (Partition)

DATE:

ALL DIMENSIONS IN INCHES

TOLERANCES
GENERAL: +/- 1/8"

DRAWN

CHECKED

A2 SCALE: 1:5

DRAWING No
RH-010

SHT 10 OF 12

DRAWING No
RH-011

SHT 11 OF 12

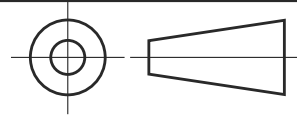

THIRD ANGLE PROJECTION

ISSUE	REVISION	DATE

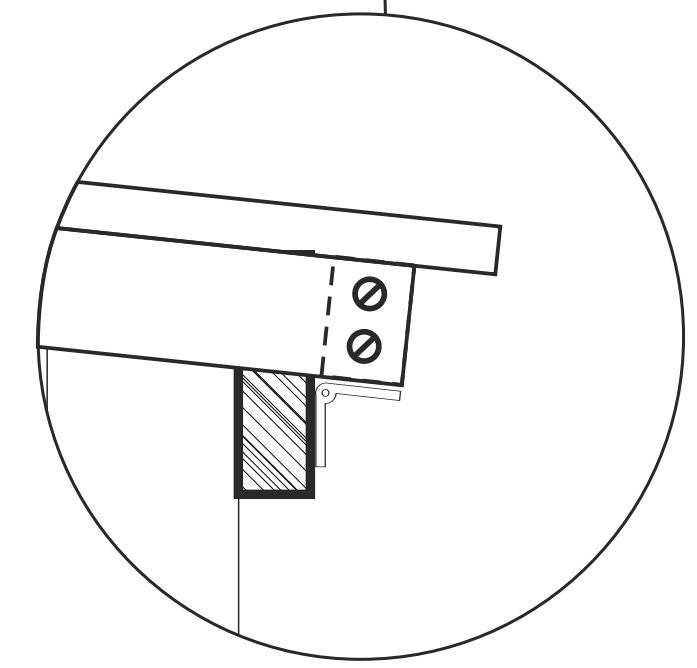
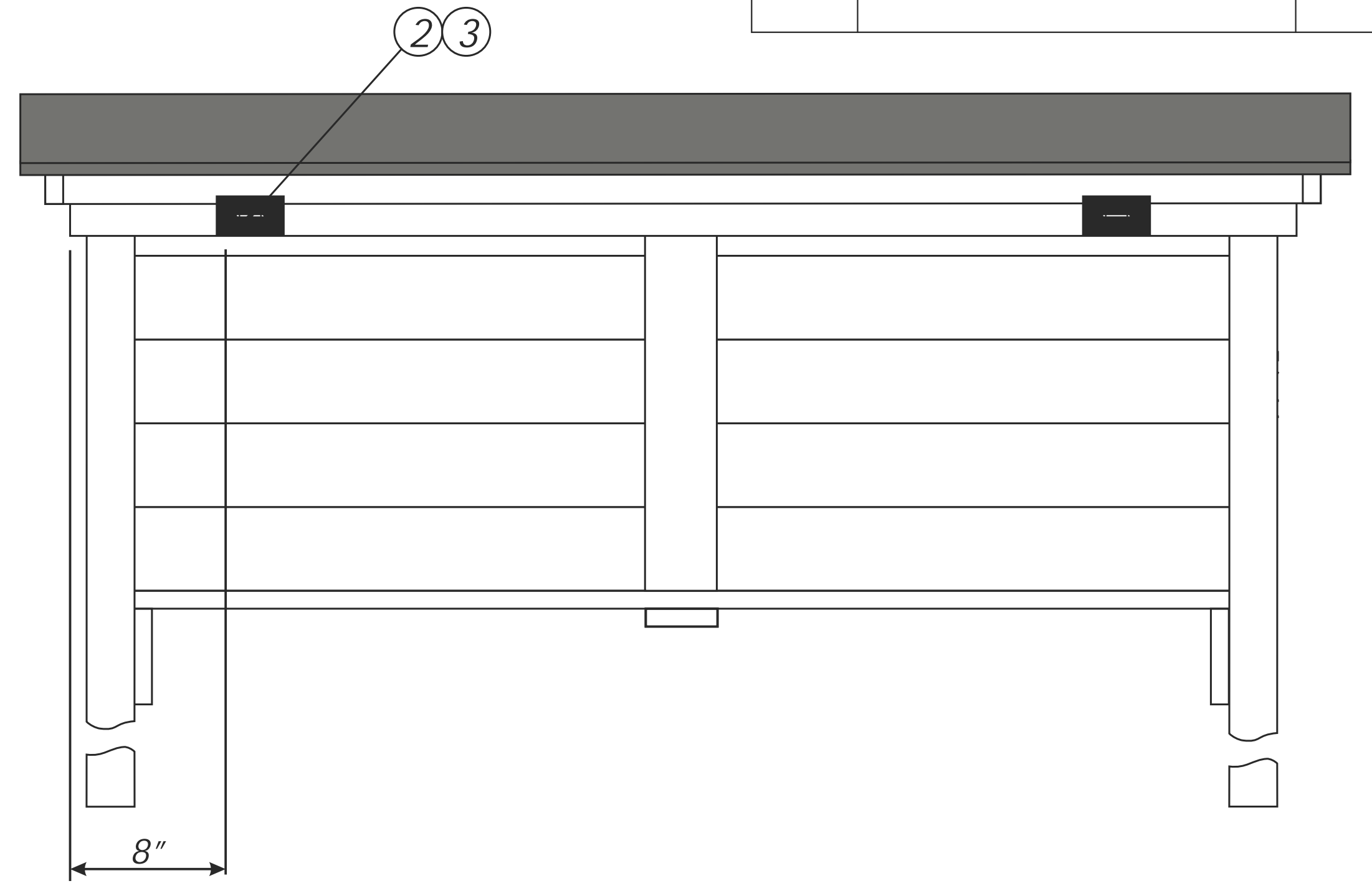
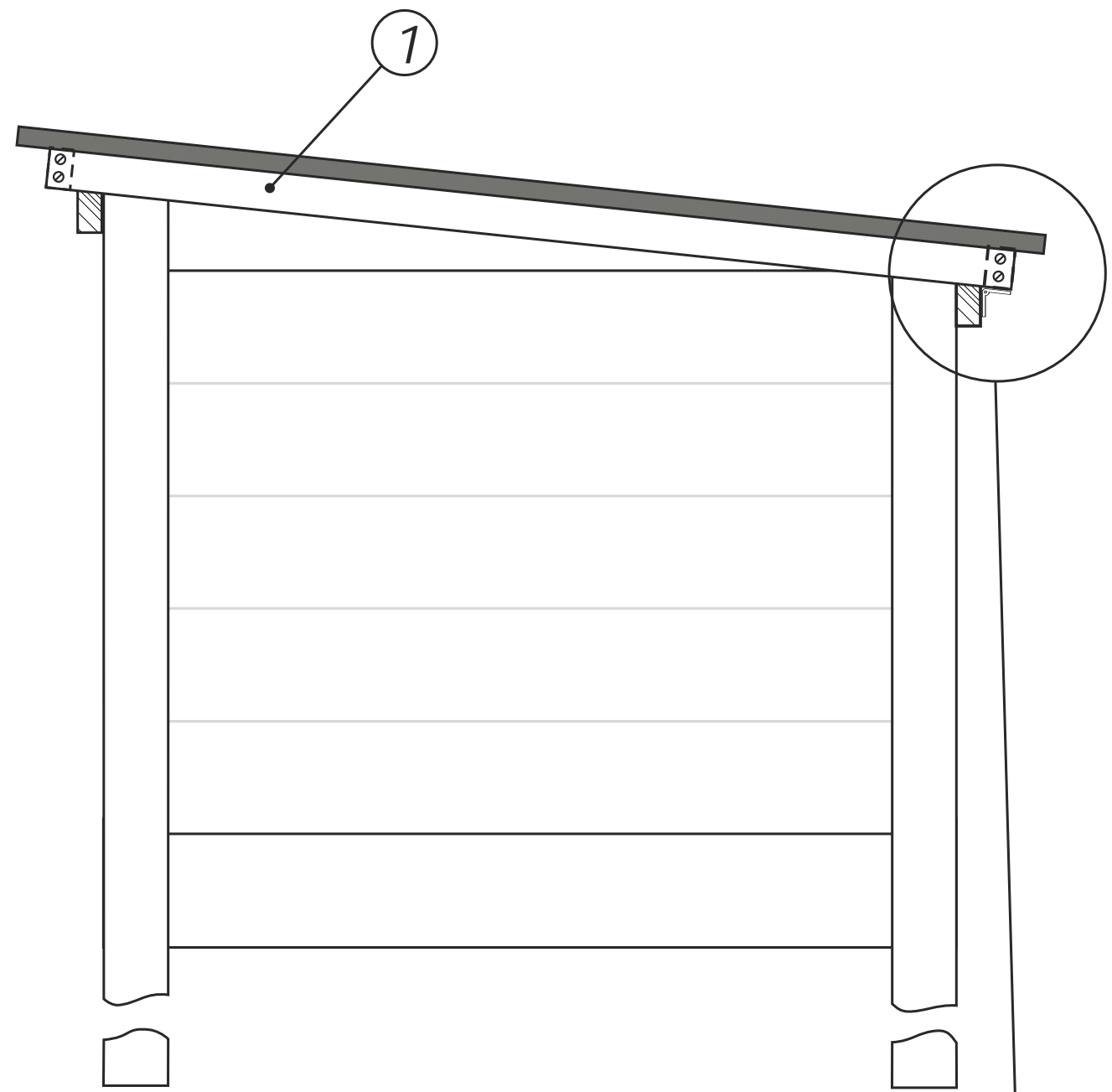

1	Roof	DRG RH-007	1
2	Hinges	2"	2
3	CSK Screws	To suit hinges	
4	Roofing Felt	Cut to size	1
5	Galvanized Clout Nails	1/2"	
No.	DESCRIPTION	MATERIAL	QTY



www.rays-shed.co.cc

TITLE
RABBIT HUTCH
ASSEMBLY (Roof)

DATE:

ALL DIMENSIONS IN INCHES

TOLERANCES
GENERAL: +/- 1/8"

DRAWN

CHECKED

A2 SCALE: 1:5

DRAWING No
RH-011

SHT 11 OF 12

DRAWING No
RH-012

SHT 12 OF 12

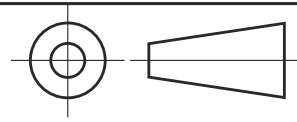

THIRD ANGLE PROJECTION

ISSUE	REVISION	DATE

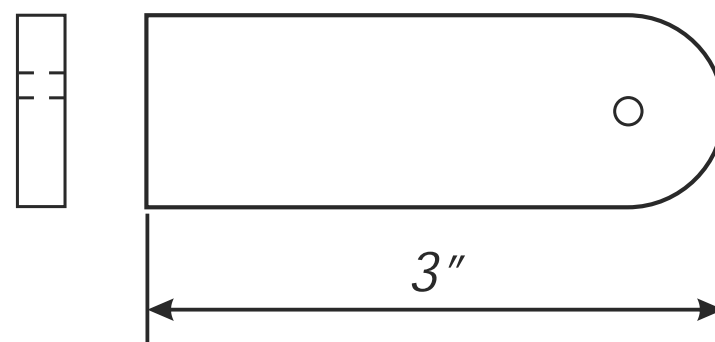
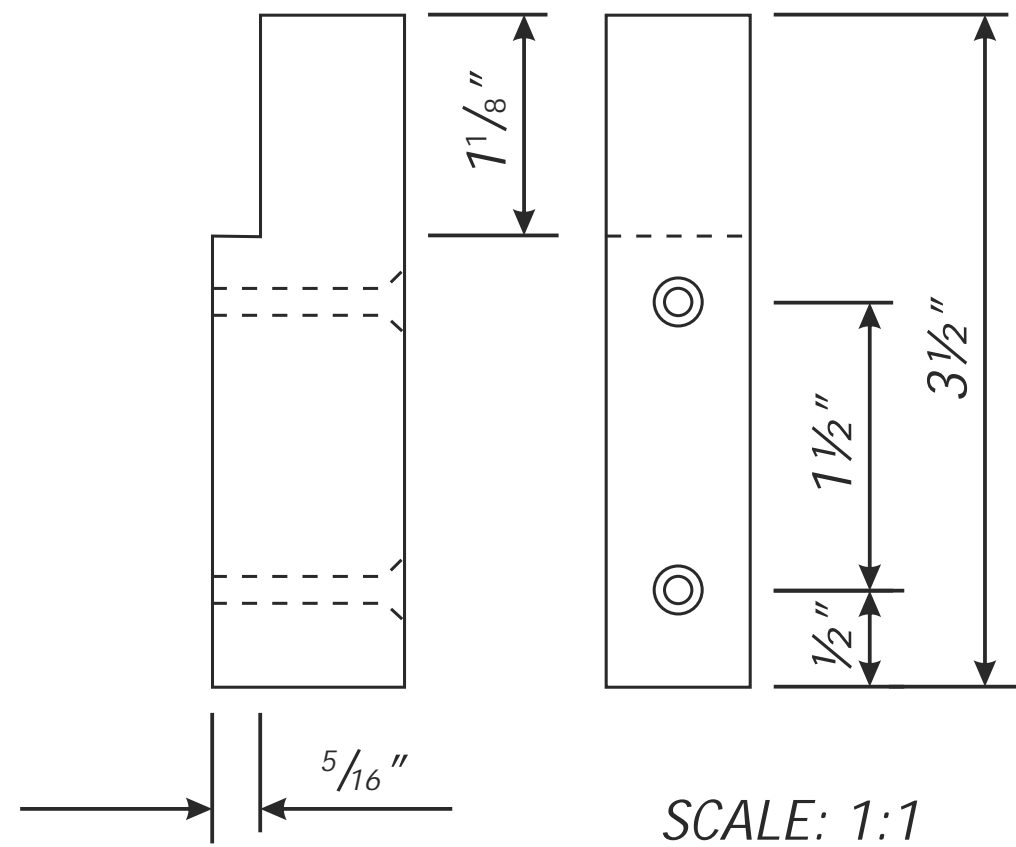
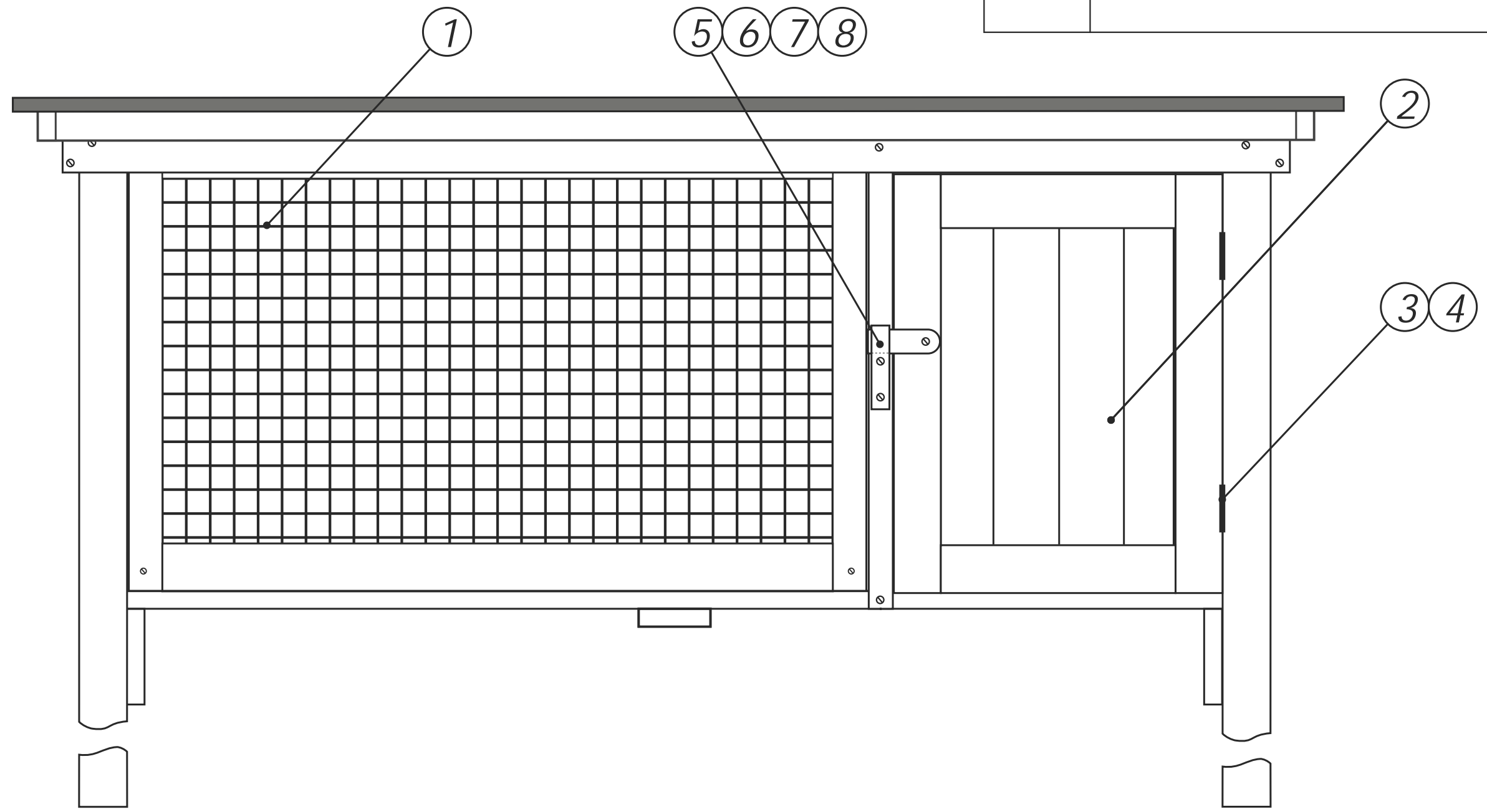
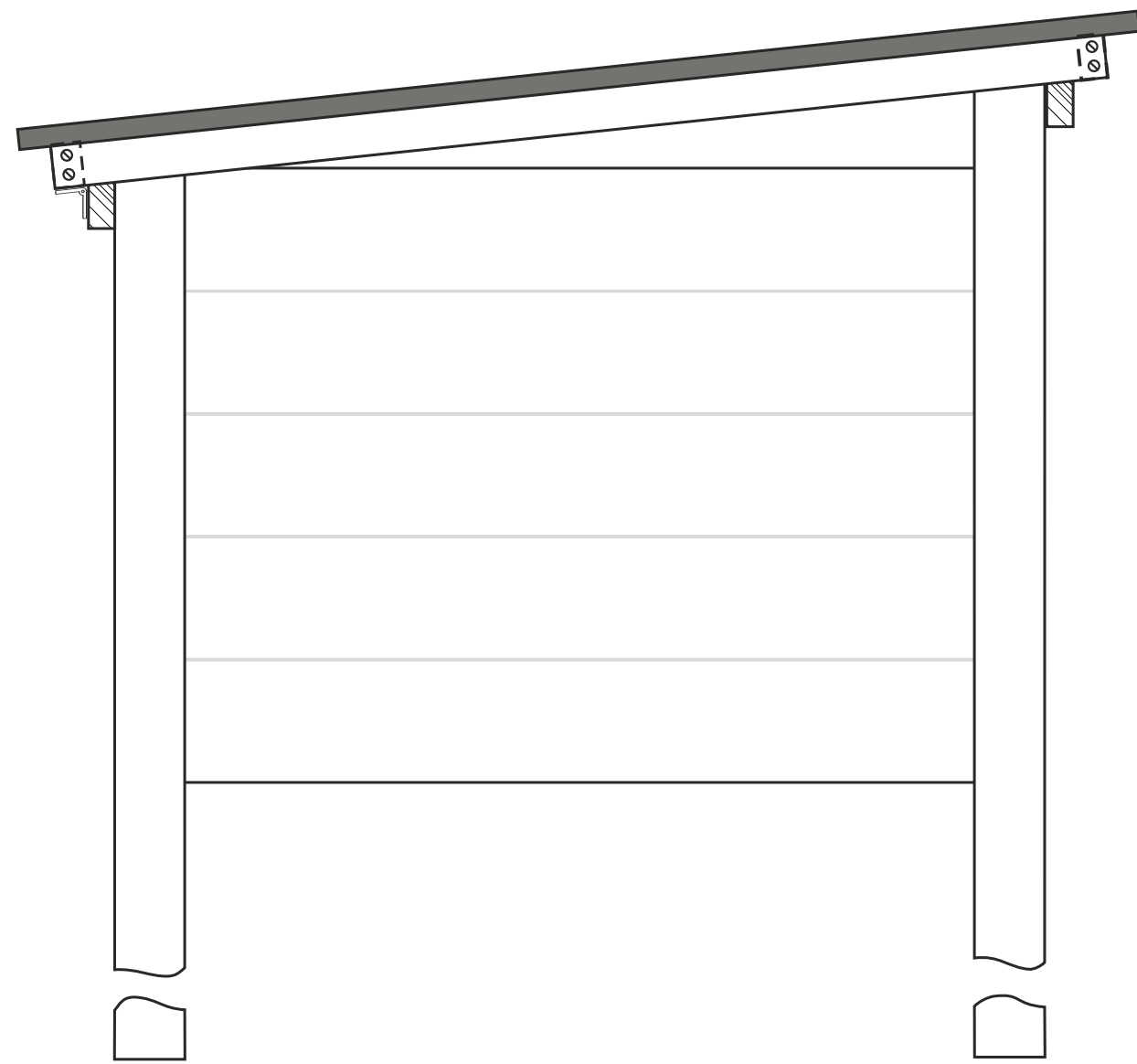

1	Front	DRG RH-005	1
2	Door	DRG RH-004	1
3	Hinges	2"	2
4	CSK Screws	to suit hinges	
5	Latch Block	1 x 3/4" x 3 1/2"	1
6	Latch	1 x 1/4" x 3"	1
7	CSK Screws	No. 8 x 1 1/2"	2
8	Round Head Screw	No. 10 x 3/4"	1
No.	DESCRIPTION	MATERIAL	QTY



www.rays-shed.co.cc

TITLE
RABBIT HUTCH
ASSEMBLY (Doors)

DATE:

ALL DIMENSIONS IN INCHES

TOLERANCES
GENERAL: +/- 1/8"

DRAWN

CHECKED

A2 SCALE: 1:5

DRAWING No
RH-012

SHT 12 OF 12